

4

3

2

1

THIS DRAWING IS UNPUBLISHED. RELEASED FOR PUBLICATION, 19 .
 © COPYRIGHT 19 BY AMP INCORPORATED. ALL RIGHTS RESERVED.

| LOC | DIST | REVISIONS | | | |
|-----|------|----------------------|---------|-----|------|
| P | LTR | DESCRIPTION | DATE | DWN | APVD |
| G | 86 | | | | |
| | D | REV PER 0G3A-0637-01 | 030CT02 | JR | MS |

- ① TIN PLATE 0.00381 [0.000150] MIN THK PER MIL-T-10727
- ② CLEANED

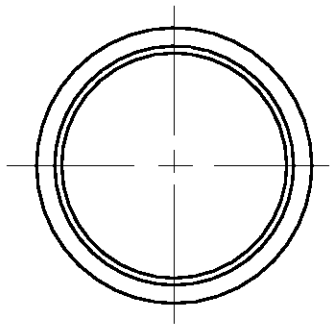
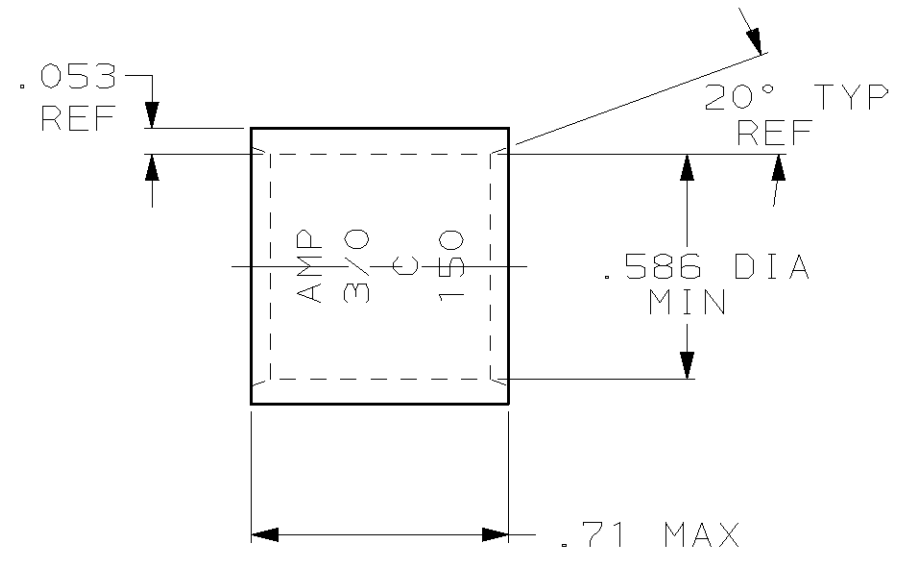

| | | |
|----------|---|-----------------|
| OBSOLETE | ② | 1-324445-0 |
| | ① | 324445 |
| FINISH | | AMP PART NUMBER |

| | | | | | | | | | | | | | | | |
|--|------------------|-------------------------|--|-------|----|-------|----|-------|----|-------|----|--------|----|----------------|---------|
| THIS DRAWING IS A CONTROLLED DOCUMENT FOR AMP INCORPORATED. IT IS SUBJECT TO CHANGE AND THE CONTROLLING ENGINEERING ORGANIZATION SHOULD BE CONTACTED FOR THE LATEST REVISION. | | DWN DK SCHRUM 01JUL96 | AMP AMP Incorporated Harrisburg, PA 17105-3608 | | | | | | | | | | | | |
| DIMENSIONS: mm [INCHES] | | CHK WJ VOCKROTH 02JUL96 | | | | | | | | | | | | | |
| TOLERANCES UNLESS OTHERWISE SPECIFIED: | | APVD JL MECKLEY 02JUL96 | NAME WIRE SPLICE, PARALLEL, AMPPOWER, WIRE SIZE: 3/0 AWG | | | | | | | | | | | | |
| <table border="0"> <tr><td>0 PLC</td><td>±-</td></tr> <tr><td>1 PLC</td><td>±-</td></tr> <tr><td>2 PLC</td><td>±-</td></tr> <tr><td>3 PLC</td><td>±-</td></tr> <tr><td>4 PLC</td><td>±-</td></tr> <tr><td>ANGLES</td><td>±-</td></tr> </table> | | 0 PLC | ±- | 1 PLC | ±- | 2 PLC | ±- | 3 PLC | ±- | 4 PLC | ±- | ANGLES | ±- | PRODUCT SPEC - | SIZE A3 |
| 0 PLC | ±- | | | | | | | | | | | | | | |
| 1 PLC | ±- | | | | | | | | | | | | | | |
| 2 PLC | ±- | | | | | | | | | | | | | | |
| 3 PLC | ±- | | | | | | | | | | | | | | |
| 4 PLC | ±- | | | | | | | | | | | | | | |
| ANGLES | ±- | | | | | | | | | | | | | | |
| MATERIAL COPPER PER ASTM B-75 ANNEALED | FINISH SEE TABLE | APPLICATION SPEC - | CAGE CODE 00779 | | | | | | | | | | | | |
| | | WEIGHT .024 lbs | DRAWING NO C-324445 | | | | | | | | | | | | |
| | | CUSTOMER DRAWING | SCALE 2:1 SHEET 1 OF 1 REV D | | | | | | | | | | | | |